

40W 9xxnm Uncooled Multimode Laser Diode Module

BMU40-9xx-02-R

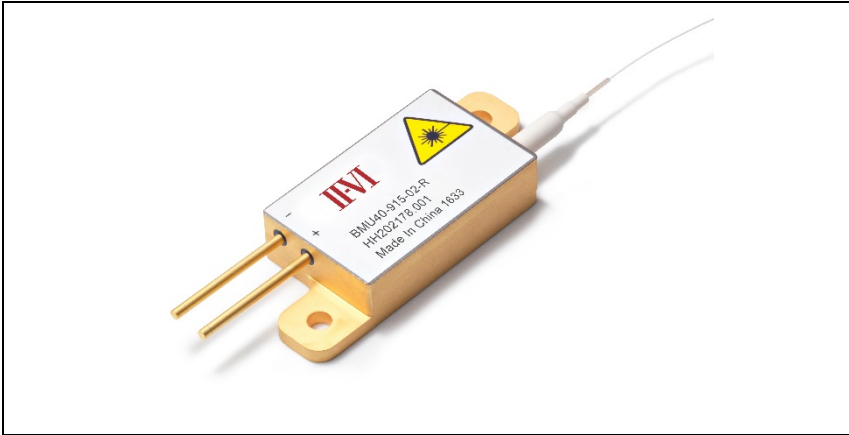

II-VI's new multimode single emitter based laser diode module BMU40-9xx-01-R has been designed to provide an increased power output enabling fiber laser and direct system manufacturers to generate higher powers with fewer modules, allowing for more compact pump configurations, greater pump block efficiency and simplification of packaging. Its compact design reduces the footprint of fiber laser pump stages.

The module features a new generation of multimode laser diodes with E2 front mirror passivation that prevents Catastrophic Optical Damage (COD) to the laser diode facet. The laser diodes are connected in series to allow for fast current switching. The module includes a feedback protection filter that protects the laser diodes from harmful fibre laser wavelength feedback light.

Features:

- Single emitter based laser diode module
- Increased output power up to 40W
- 0.22NA 106.5 μ m core multimode optical fiber with 0.16NA under-filling
- Hermetically sealed 2-pin package with floating anode/cathode
- Fibre laser feedback protection
- Standard wavelengths at 915, 940, 960 and 975nm
- High reliability
- RoHS compliant 

Applications:

- Fibre laser pumping
- Direct applications
- Material processing
- Medical

Optical Characteristics

Conditions unless otherwise stated:

Parameters at 25°C heat sink temperature and use of a thermal interface material rated for a thermal contact resistance of less than 1.0cm² K/W. Optical fibre with 106.5µm core diameter and 0.22NA.

Parameter	Min	Typ	Max	Unit	Conditions
CW Output Power	36	40		W	
Centre Wavelength BMU40-915-02-R BMU40-940-02-R BMU40-960-02-R BMU40-975-02-R	905 930 950 970	915 940 960 975	925 950 970 980	nm	At rated output power
Spectral Width (-13dB)		6		nm	
Threshold Current		0.5	0.7	A	
Operating Current			12	A	
Operating Voltage			7.5	V	12A
Wallplug Efficiency		45		%	12A
Feedback Protection	30			dB	1030-1200nm

Absolute Ratings

Parameter	Min	Typ	Max	Unit	Conditions
ESD	–		500	V	HBM, C=100pF, R=1.5 kOhm
Storage temperature	-40		85	°C	non-condensing
Lead soldering temperature	–		320	°C	
Lead soldering time	–		10	Sec	
Operating case temperature	15		60	°C	Reliability impacted if operating point deviates from reference condition
Relative humidity	5		85	%	Non-condensing
Fiber bend radius	25			mm	

Fiber Specification

Parameter	Min	Typ	Max	Unit	Conditions
Buffer diameter	230	245	260	μm	
Cladding diameter	124	125	126	μm	
Core diameter	105	106.5	108	μm	
Numeric aperture	0.2	0.22	0.24	-	
NA Filling			0.16	NA	>95% power content
Pigtail Length	1.5	-	2.5	m	Bare fiber or with connector

Package Dimensions (mm)

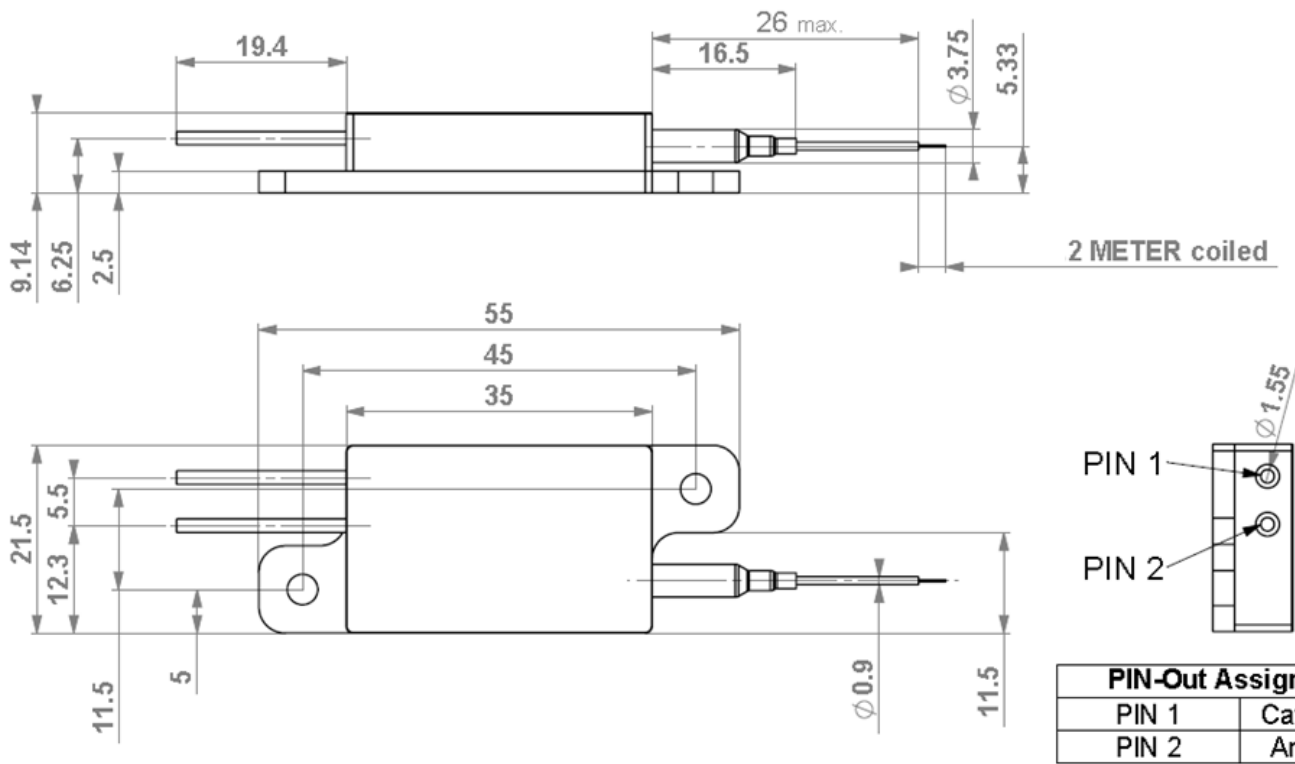

PIN-Out Assignment	
PIN 1	Cathode (-)
PIN 2	Anode (+)

RoHS Compliance



II-VI is fully committed to environment protection and sustainable development and has set in place a comprehensive program for removing polluting and hazardous substances from all of its products. The relevant evidence of RoHS compliance is held as part of our controlled documentation for each of our compliant products. RoHS compliance parts are available to order, please refer to the ordering information section for further details.

Ordering Information:

BMU40-915-02-R	40W 915nm Multimode Laser Diode Module with 0.22NA fibre
BMU40-940-02-R	40W 940nm Multimode Laser Diode Module with 0.22NA fibre
BMU40-960-02-R	40W 960nm Multimode Laser Diode Module with 0.22NA fibre
BMU40-975-02-R	40W 975nm Multimode Laser Diode Module with 0.22NA fibre

Contact Information

www.ii-vi-suwtech.com

Important Notice

Performance figures, data and any illustrative material provided in this data sheet are typical and must be specifically confirmed in writing by II-VI SUWTECH before they become applicable to any particular order or contract. In accordance with the II-VI SUWTECH policy of continuous improvement specifications may change without notice. Further details are available from any II-VI SUWTECH sales representative.

